



Inflatable Packer Manual



Purchase Date: _____

This manual belongs in Rig / Shop # _____

Aardvark Packers LLC
450 California Street
Grants Pass, OR 97526

Ph: 855-546-6488 Fax: 866-868-6665

Emergency Ph: 360-908-3283

Email: dave.baca@aardvarkpackers.com

Web: www.aardvarkpackers.com

PACKER OPERATING PROCEDURES

INTRODUCTION

The Tigre Tierra® Packer is a sliding head inflatable packer that expands radially and contracts axially as pneumatic or hydraulic pressure is applied. Steel cable reinforcement within the packer gland element permits uniform expansion over the entire length of the element and allows the outer rubber cover to extrude into borehole irregularities and fractures, creating an effective seal over the entire length of the packer gland element.

Inflation pressure is introduced into the packer through a port on the packer head that is tapped for a standard male tube connector. For inflation tubing, Aardvark Packers recommends 3/16-inch outside diameter (OD) nylon rated at 2,500 psi burst. This tubing allows the user to operate the packer under extreme hydrostatic head conditions not possible with lower pressure-rated tubing.

Four major components make up the Tigre Tierra® Packer:

- Fixed Head
- Gland Element
- Center Tube
- Sliding Head

Both packer heads are tapped with either 1/8-inch NPT or 10-32 threads to permit simultaneous use of multiple packers. The inflation fluid is transmitted through the packer in the annulus between the center tube and the gland element. All packers are shipped with a plug in the sliding head which must be replaced with a tube connector for multiple packer use.

Stamped on the circumference of the fixed head of each packer is the maximum internal pressure that can be applied when the packer is inflated to its maximum diameter. This is the pressure at which maximum gland element expansion occurs. Pressure in excess of this rated pressure voids the warranty.

NOTE: When a Tigre Tierra® Packer is confined within an open or cased borehole of known diameter, it is possible to exceed the rated free-air pressure without jeopardizing the warranty. See the pressure curves in this booklet or call Aardvark Packers LLC for details.

*CAUTION: Compressed gases, such as nitrogen and compressed air, are extremely dangerous, and misuse of these gases can cause serious injury. **Fallow instructions on the compressed gas bottles.***

*If the packer is tested or inflated above ground, do not test or inflate above 25% of the unconfined rated pressure stamped on the fixed head of the packer. **Stay clear of either end of the packer when testing or inflating the packer above ground.***

Gases such as nitrogen and compressed air are extremely dangerous. Misuse of the gases or of the packers that they operate can result in serious injury. Use extreme caution.

Either pneumatic or hydraulic packer inflation is acceptable, although pneumatic inflation is recommended for standard packer system. Recommended inflation fluids include compressed air, inert gases (such as nitrogen or carbon dioxide) and water.

Exposure to hydrocarbons will damage the packer gland element, and subsequent use will void the Aardvark Packers warranty. If the packer is to be operated under these conditions, it must be Viton®-clad.*

Prior to first use, all connections made on site should be tested at 25 PSI for leaks, and the gauge or regulator on the source of inflation pressure should be calibrated to assure accurate readings. Faulty regulators are a prime case of packer failure.

Aardvark's Tiger Tierra® Packers are tested and serialized before shipping. The serial number appears on the circumference of the fixed head, next to the maximum internal packer pressure.

SINGLE PACKER OPERATION

The fixed head is normally oriented uphole during single packer operation. After connecting the inflation tube to the connector on the fixed packer head, run the packer to the desired depth on the drill rods, grout rods or iron pipe. Then connect the inflation tube to the pressure regulator.

With the regulator adjustment lever backed off to zero pressure, open supply valve on the source of inflation pressure. Slowly and gradually increase pressure to the packer by adjusting the regulator. Final gauge pressure should not exceed the total of rated packer pressure plus hydrostatic pressure above the packer. If you have any questions about inflation pressure, please contact Aardvark Packers LLC.

When testing or grouting through the packer is completed, release inflation pressure and allow enough time for the gland element to relax to its at – rest diameter. You can tell when the gland element is properly deflated by inserting the inflation tubing into a cup of water. When bubbles cease to appear in the water, the element is deflated. You can then retrieve the packer or reposition it in the borehole for further testing.

If your system includes a pump and in-line adapters are not used, be sure to allow extra wire between the sliding head and the pump.

The packer also will function with the sliding head oriented uphole. However, care must be taken when retrieving a packer set in this orientation. In an uncased, irregular borehole, the sliding head may catch on a fracture during retrieval. Continued upward force will cause the gland element to expand mechanically and lodge in the hole.

STRADDLE PACKER OPERATION

For straddle or zone packer operation, the lower packer is oriented with the fixed head uphole. The center tube is capped. Add lengths of perforated steel tubing consistent with desired zone lengths to the fixed head of the lower packer. Connect a length of inflation tubing to the lower packer to join the two packers.

With the sliding head oriented uphole, connect the upper packers to the perforated steel tubing and the inflation tube from the lower packer. Finally, connect inflation tubing to the sliding head of the uphole packer and begin running the packers into the borehole.

* Viton is a registered trademark of Dupont.

INFLATABLE PACKER MAINTENANCE

GLAND ELEMENT REPLACEMENT

1) Clean up the surface of the packer center tube by removing wrench marks and burrs with emery cloth or file.

NOTE: Failure to do this may cause seal damage in Step 2.

2) Unthread the sliding head from the gland element fitting and remove from the packer.

3) Unthread the gland element from the fixed head and slide it down and off of the center tube.

4) Inspect the O-ring on each packer head and replace if required.

5) Inspect the seals in the sliding head and replace if required.

6) Slide the new gland element over the center tube and thread it to the fixed packer head.

6.5) Apply 2 wraps of clear shipping tape around the threads of the center tube. This will assist in not tearing the seals as the head is slid past.

7) Push the sliding head on to the center tube and thread it into the gland element.

8) Attach the inflation tube to the fixed head and check for air leaks at all connections before running the packer into the borehole.

CAUTION: Do not test or inflate above 25% of the unconfined rated pressure.

**UNCONFINED
PRESSURE
CURVES**

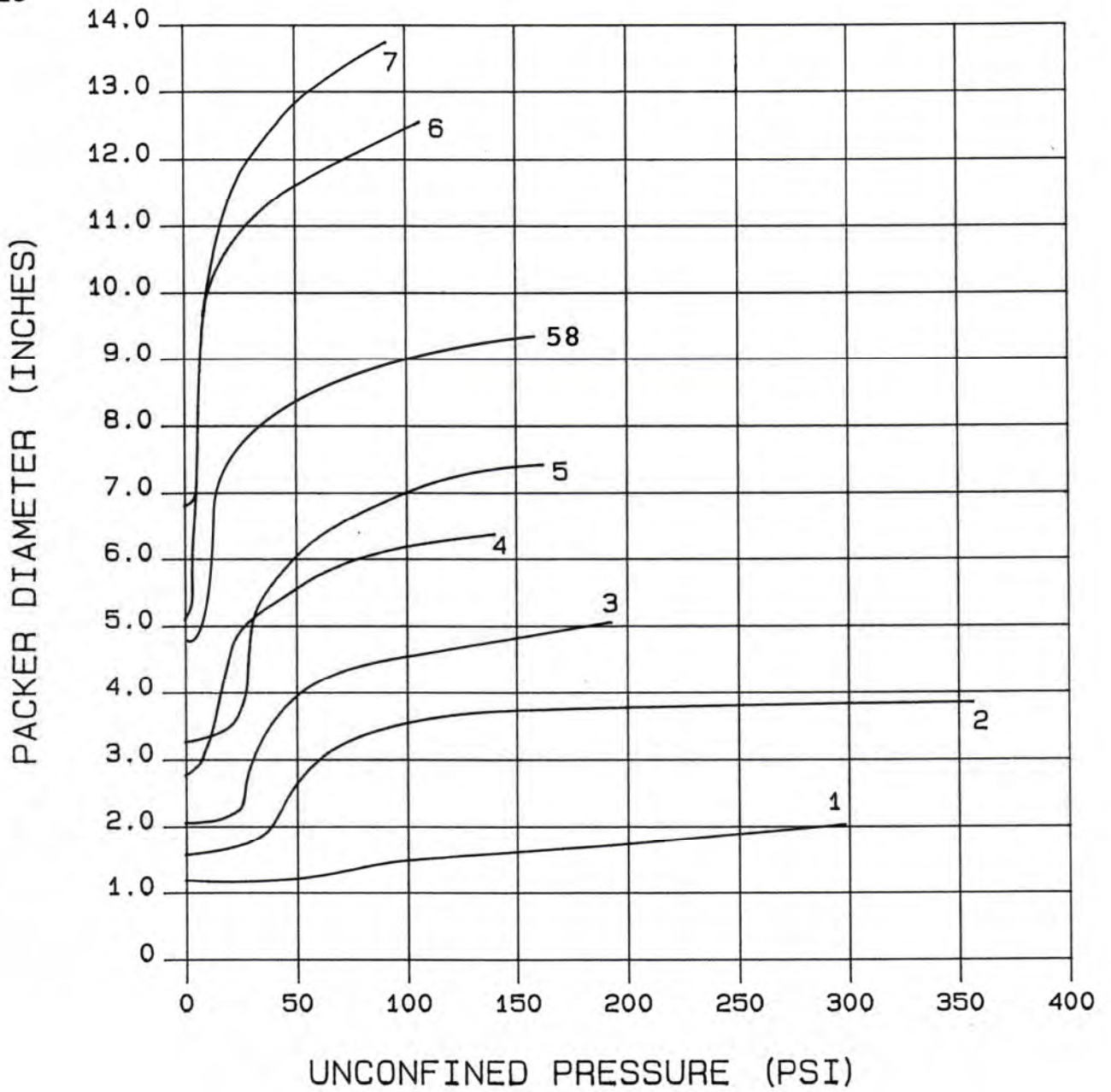

Legend

No.	Model
1	12
2	23B
3	34B
4	36
5	47
58	58 (New Size)
6	610
7	713

**CONFINED
PRESSURE
CURVES**

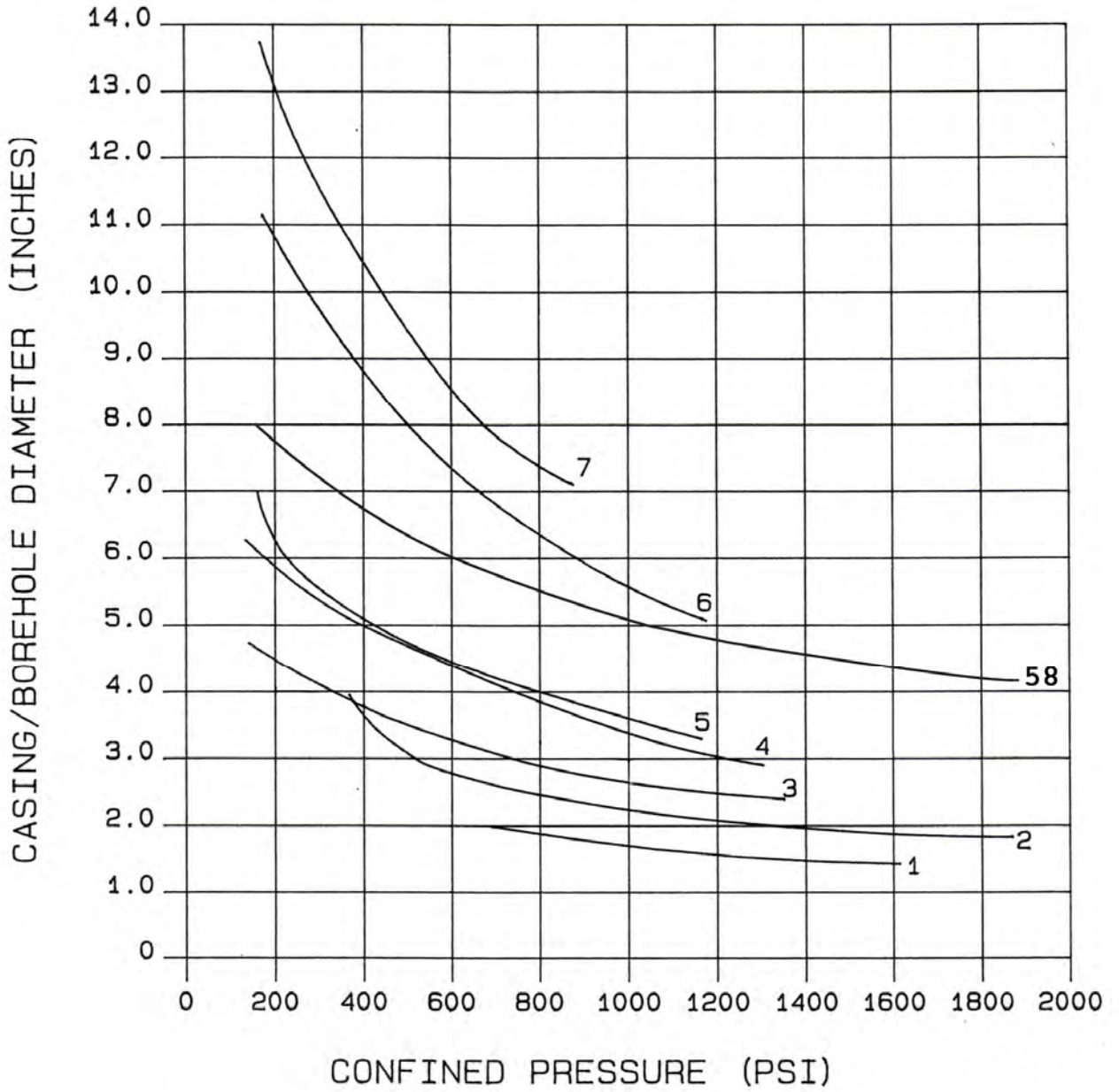

Legend

No.	Model
1	12
2	23B
3	34B
4	36
5	47
58	58 (New Size)
6	610
7	713

Inflatable Packer
ASSEMBLY
MODEL 12 - 36

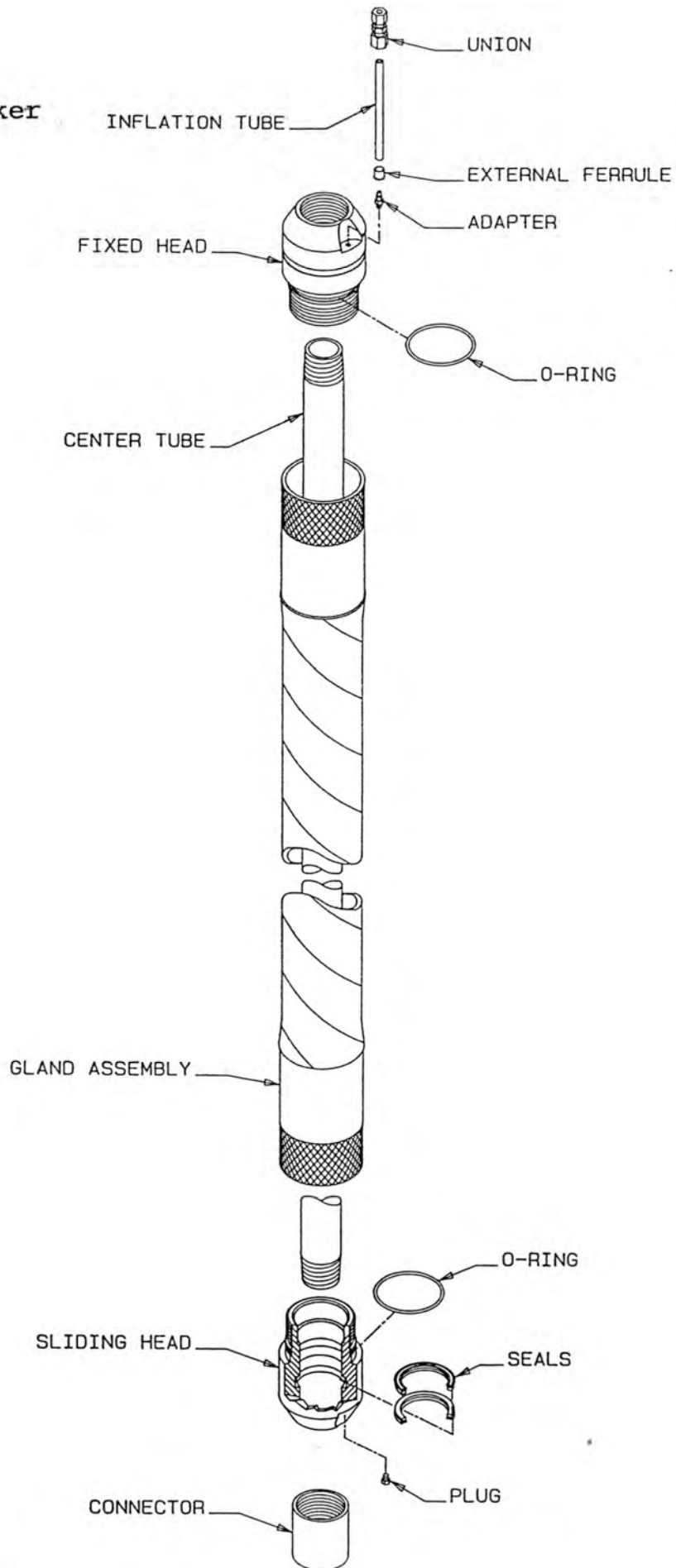

Inflatable Packer
ASSEMBLY
MODEL 47 - 713

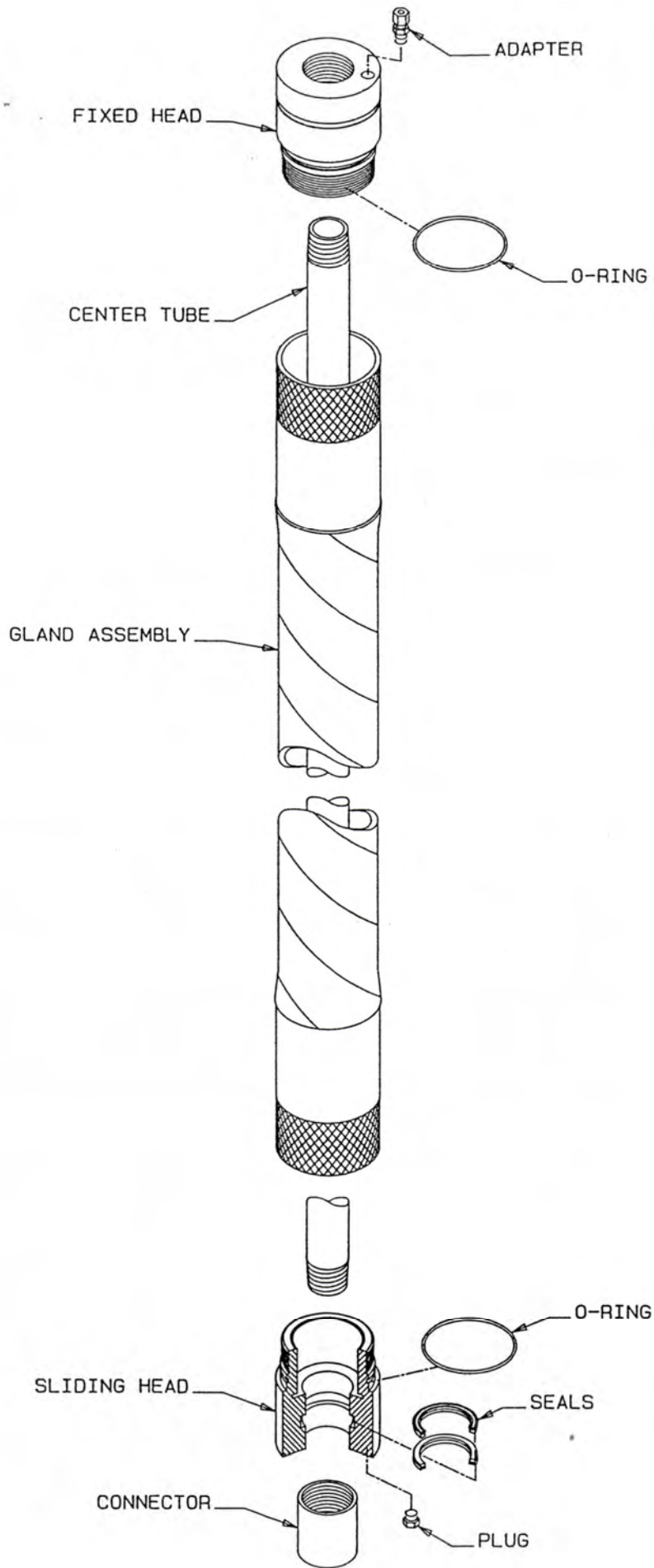

Inflatable Packers Parts List:

Model	12	23B	23B	23B	34B	34B	34B	36	36	36	47	58	610	713
Gland	30"	15"	30"	60"	15"	30"	60"	15"	30"	60"	30"	30"	49"	49"
Center Tube	.375"	.510"	.510"	.510"	1.0"	1.0"	1.0"	1.25"	1.25"	1.25"	1.25"	1.25"	2.5"	3.0"
Fixed Head	9778	8068	8068	8068	9250	9250	9250	9363	9364	9364	8276	30036	9454	9359
Sliding Head	9779	9395	9395	9395	9251	9251	9251	9363	9363	9363	8275	30037	9455	9360
Center Tube	9780	8545	8320	7770	9603	9252	9479	8518	7519	9238	7519	7519	9458	9358
Gland Assembly	9770	8497	7311	8465	9410	9200	9412	9914	9355	9394	8489	300019	9318	8569
O-Ring	9782	7894	7894	7894	8970	8970	8970	8466	8466	8466	8488	8488	9391	9361
Seal	9781	7775	7775	7775	7778	7778	7778	7520	7520	7520	7520	7520	9453	5322
Adapter	7310	7310	7310	7310	7310	7310	7310	7310	7310	7310	7724	7724	7958	7958
Plug	7316	7316	7316	7316	7316	7316	7316	7316	7316	7316	7725	7725	7725	7725
External Ferrule	8512*	8512*	8512*	8512*	8512*	8512*	8512*	8512*	8512*	8512*	-	-	-	-
Inflation Tube	8463*	8463*	8463*	8463*	8463*	8463*	8463*	8463*	8463*	8463*	-	-	-	-
Union	9477*	9477*	9477*	9477*	9477*	9477*	9477*	9477*	9477*	9477*	-	-	-	-
Connector	9787	7312	7312	7312	9257	9257	9257	9373	9373	9373	9373	9373	9790	9555

*These parts also are available as kit # 9564

Inflatable Grout Packers Parts List:

Model	23B	23B	23	34B	34B	34B	36	36	36	47	58
Gland	15"	30"	60"	15"	30"	60"	15"	30"	60"	50"	30"
Assembly	10075-X	10074-X	10078-X	9411-X	9249-X	9413-X	9415-X	9365-X	9416-X	8314-X	30035X
Fixed Head	*	*	*	9250	9250	9250	9364	9364	9364	8276	30036
Sliding Head	10077	10077	10077	9862	9862	9862	10079	10079	10079	10083	30037X
Center Tube	*	*	*	9603-X	9252-X	20035-X	8518-X	7519-X	9238-X	20140-X	20140X
Center Tube Wldt.	20138-X	20003-X	20139-X	-	-	-	-	-	-	-	-
Gland Assembly	8497-X	7311-X	8465-X	9410	9200	9412	9414	9355	9394	8489	300019
O-Ring	7894	7894	7894	8970	8970	8970	8466	8466	8466	8488	8488
Seal	7776	7776	7776	7778	7778	7778	7520	7520	7520	7520	7520
Scraper	10080	10080	10080	10081	10081	10081	10082	10082	10082	10082	10082
Adapter	7310	7310	7310	7310	7310	7310	7310	7310	7310	7724	7724
External Ferrule	8512**	8512**	8512**	8512**	8512**	8512**	8512**	8512**	8512**	8512**	-
Inflation Tube	8463**	8463**	8463**	8463**	8463**	8463**	8463**	8463**	8463**	8463**	-
Union	9477**	9477**	9477**	9477**	9477**	9477**	9477**	9477**	9477**	9477**	-

*Models 23B are sold with a fixed head centre tube weldment.

** These parts also are available as kit #9564

**Inflatable Grout
PACKER ASSEMBLY**

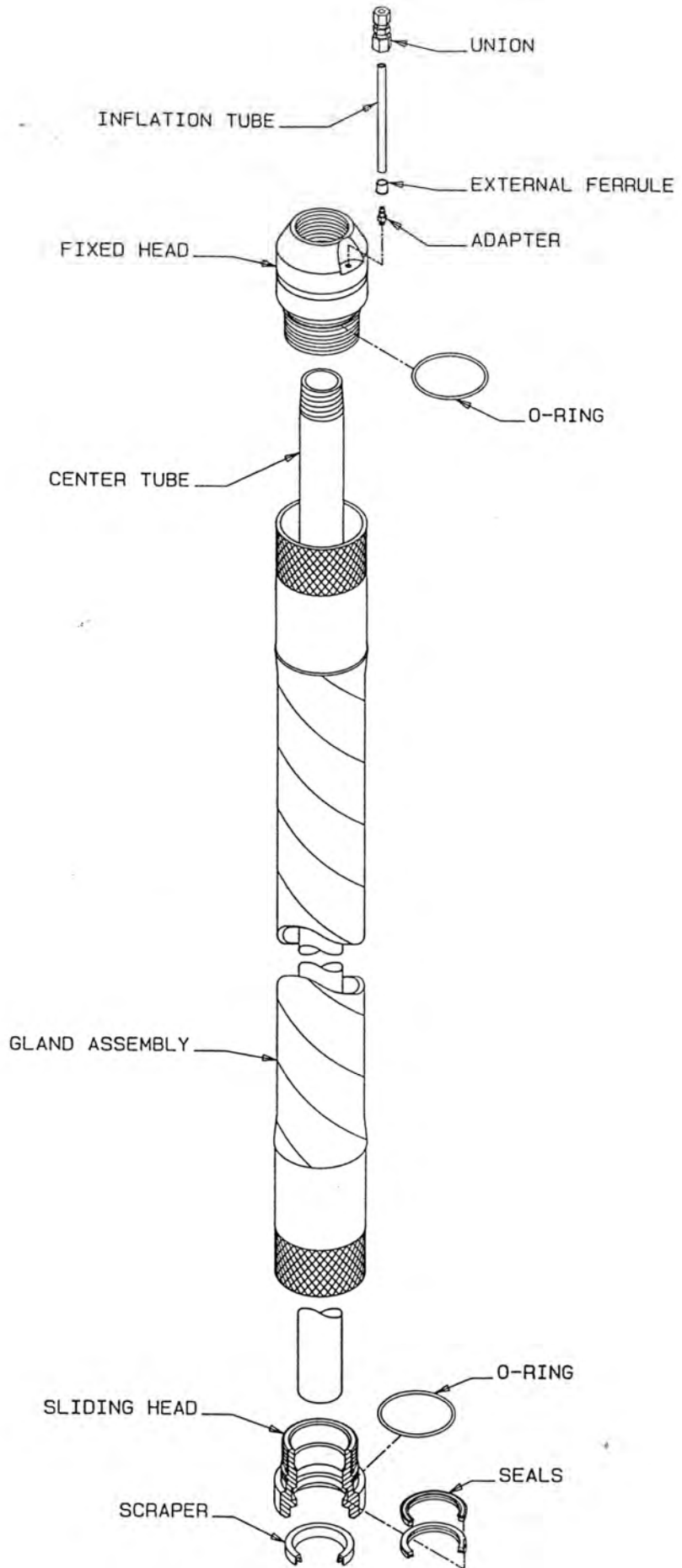

ADDITIONAL INFORMATION

CONDITIONS OF SALE

- Prices** All prices shown are current, but are subject to change without notice. All are based on standard domestic packaging and so not include special overseas packaging or other requirements. Dealer, contractor and OEM discounts for volume orders are available.
- Terms** Prior credit approval and non-delinquent status are necessary before shipping on open accounts. Our open account terms are Net 30 days. A 1-1/2% per month (18% per annum) charge is made on accounts exceeding 30 days. Accounts exceeding 60 days are considered delinquent.
- Shipping** All shipments are F.O.B. shipping point. This means the carrier accepts all responsibility upon accepting the shipment at our dock. Therefore, any claims for loss or damage must be settled without delay between you and the carrier.
- Claims & Returns** Claims for shortages or inaccurate filing or orders must be made to Aardvark Packers LLC within 10 days after receipt of goods. (An authorization number for return of goods will then be issued.) Include a copy of the invoice and bill of landing on which the goods were purchased. Reference the assigned authorization number. There is a 25% restocking charge on any items returned for credit or exchange when the error is not ours. Items returned without prior authorization will be refused.
- Notice to The Buyer** AARDVARK PACKERS LLC WILL ENDEAVOR TO FURNISH SUCH ADVICE AS IT MAY BE ABLE to supply with reference to use by Buyer of any material purchased, but AARDVARK PACKERS LLC makes no GUARANTEES and assumes no obligation or liability for the advice given verbally or in print or the results obtained. **Buyer assumes all risk and liability** which may result from the use of any material, whether used singly or in combination with other products. No suggestion for use shall be construed as a recommendation for its use in infringement on any existing patent.

WARRANTY & LIMITATION OF REMEDIES

- Warranty** Aardvark Packers LLC warrants that for a period of three (3) months from the date of purchase, the packers manufactured and sold by Aardvark shall be of workman-like quality and will operate properly if used and maintained properly.
- THERE ARE NO WARRANTIES, EXPRESS OR IMPLIED, THAT EXTEND BEYOND THE DESCRIPTION ON THE FACE THEREOF.
- Limitation of Remedies** The buyer's exclusive remedy under this Warranty shall be the replacement or repair of any item proved to be defective; Aardvark Packers LLC shall not be liable for any incidental or consequential damages.
- Any claims made under this Warranty must be presented to Aardvark Packers LLC within three (3) months after delivery of the product to the buyer. Aardvark Packers LLC shall have a reasonable time after notice of a claim made under this Warranty in which to exercise its option to replace or repair the item, and shall have the right to require that the allegedly defective item be returned, at the buyer's expense, before recognizing any claim.

This Warranty shall not apply if the buyer repairs or alters an item without the prior written consent of Aardvark Packers LLC, or if the item is subject to abuse or misuse, neglect or accident.

IMPORTANT NOTICE:

**Aardvark
Packers LLC
Is Not Responsible
For Any Changes
Or Alterations To
This Product.**

Unless otherwise agreed in writing, Aardvark Packers LLC disclaims any warranties with respect to this product, the safety or suitability thereof, or the results obtained, whether expressed or implied, including, without limitation, any implied warranty of merchantability or fitness for a particular purpose and/or any other warranty. Buyers and users assume all risk, responsibility, and liability whatsoever for any and all injuries (including death), losses, or damages to persons or property arising from the use of this product, whether or not occasioned by the seller's negligence or based on strict product liability or principles of indemnity or contribution. Aardvark Packers LLC neither assumes nor authorizes any person to assume for it any liability in connection with the use of this product.

**AARDVARK PACKERS LLC
PO Box 5786
Hillsborough, NJ 08844**